

Call cost saving features

The unit provides three main ways to reduce your call costs, particularly when paired SIMs are used in both the unit and your mobile phone:

- Outgoing call routing** - The unit chooses the least cost route (via mobile or land line) depending on the outgoing number that you dial.
 Dial **0#9120** to enable outgoing call routing. Dial **0#9130** to force all calls via mobile or **0#9140** to force all calls via the land line. Dial **0#9110** to check the current call routing status.
 A single call can be forced to use the landline by pressing the **R** or **Recall** button of the connected phone or by quickly pressing and releasing its hook switch.
- Land line dial through** - Allows an incoming call received via the mobile connection to make a new outgoing call using the landline connection. When the unit answers, the unit will respond according to how the options have been set:
 Dial **0#9620** to allow only callers stored in the unit's phonebook to make dial through calls. Dial **0#9630** to require callers to enter a PIN code before they can make dial through calls. Dial **0#9640** to allow any caller to make a dial through call. Dial **0#9650** to prevent dial through calls. Dial **0#9610** to check the current dial through status. If you make an error while dialling, press **##** to begin a new call without hanging up.
- Forward from land line** - Transfers incoming calls received via the land-line connection to a number of your choice via the mobile connection.
 Dial **0#4270** to set the number to which calls should be forwarded (this must be set first). Dial **0#4220** to make the phone (that is connected to the unit) ring while a call is being forwarded - this allows the call to be answered either at the connected phone or at the forwarded number. Dial **0#4230** to forward calls without making the connected phone ring. Dial **0#4240** to make the connected phone ring while forwarding calls and to play an announcement to callers. Dial **0#4250** to forward calls and make an announcement to callers without making the connected phone ring. Dial **0#4260** to cancel call forwarding. Dial **0#4210** to check the current call forwarding status.

This quick start guide will help you to set up, switch on and begin using your fixed cellular terminal unit, particularly for the purposes of saving costs through intelligent call routing. For further information on all features, please refer to the full user guide available within the 'download section' at:

www.burnsidetelecom.com or www.burnsidetelecom.co.uk

Insert your SIM card

Note: Ensure that the unit is switched off before inserting your SIM card. Insertion is most easily achieved with the unit carefully placed upside down.

1 Use a thin object to press the tray eject button. Fully remove the tray.

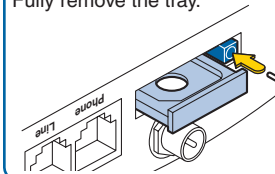

2 Place the SIM card into the tray so that the contacts are facing up.

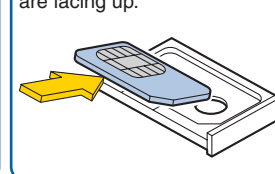

3 Slide the tray back into the slot and press it all the way in.



Position the unit

Place the unit in a suitable location, but not directly next to your telephone and at least one metre from the intended antenna position, in order to avoid interference. You will need close access to both a mains power socket and a working telephone socket.

Connect the phone line

- Using the supplied phone line, connect the smaller of the two plugs to the socket on the T910 rear panel, labelled 'Line'.
- Connect the other end of the cable to a nearby telephone wall socket.
Note: Ensure that the cable does not cause a trip hazard.

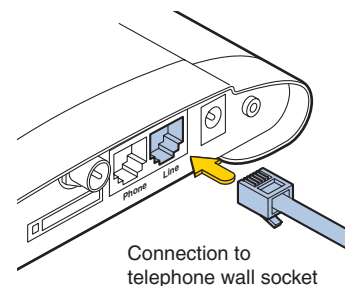

Connect a telephone

- 1 Connect the supplied cable adapter to the socket on the rear panel, labelled 'Phone'. Your phone may have a connector that fits directly into the unit's 'Phone' socket, in which case the adapter is not needed.
- 2 Connect your standard telephone to the cable adapter.

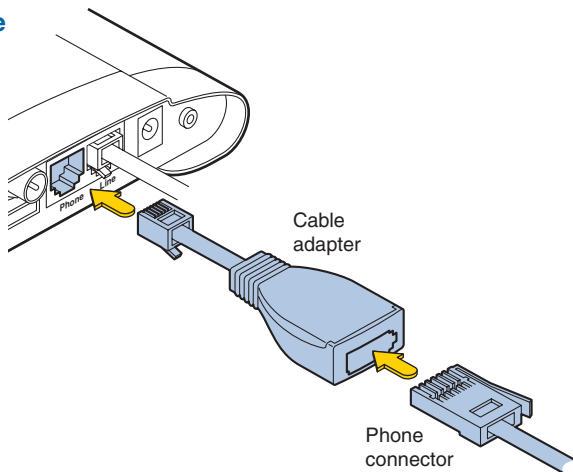

Connect the magnetic mount antenna

- 1 Assemble the antenna by screwing the upper section into the base until it is finger tight.
- 2 Position the antenna where required, if possible on a secure metal surface.

Note: Keep the antenna base away from monitor screens, televisions, credit cards or any device affected by magnetism.

- 3 Feed the antenna cable to the rear of the unit, insert the connector into the antenna socket and twist the collar until finger tight.

Note: Ensure that the cable does not cause a trip hazard.

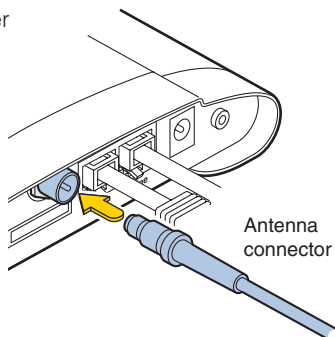

Connect power

- 1 Attach the connector from the power adapter to the socket on the far right of the rear panel.
- 2 Plug the power adapter into a nearby mains outlet. The unit will begin operation as soon as power is applied.

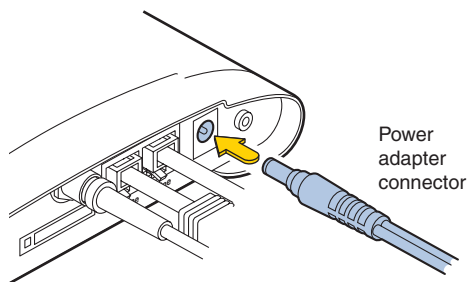

Basic operation

Once connected, powered on and ready to operate, the unit will show the time, date, the name of the current network and an indication of the signal strength:

Date and time
To alter, pick up the handset, press **0#550** and follow the screen instructions (when prompted, use zero as a confirmation button).

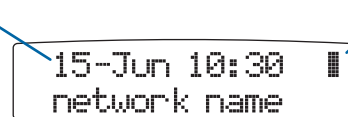

Signal strength
The height of the bar in the top right corner indicates signal strength.

To make a call, lift the handset and dial the number as usual. The unit will use either the mobile or landline as specified by the outgoing call settings (see rear page). To force the use of the land line, press your phone's **R** or **Recall** button or briefly press and release the handset hook switch (display will show 'Line connected') and dial.

To make international calls, lift the handset and press the zero button until '+' is displayed, then enter the standard country code.

Using the menu

Lift the handset and press **0#** on the keypad to enter the menu. You can then:

- Navigate the menu using these control keys:
 - *** to go back/up; **#** to go down/forward; **0** to enter/confirm
- Or enter a code to reach a particular menu item:

- | | |
|---------------------------------|--------------------------------------|
| 1 Phonebook | 5 Settings |
| 1 Search | 1 Terminal settings |
| 2 Add entry | 2 Phone settings |
| 3 Edit | 3 Network settings |
| 4 Status | 4 Input/Output settings |
| 5 Erase | 5 Set clock |
| 2 Messages | 6 Special function |
| 1 Write message | 1 Lock outgoing calls |
| 2 Inbox | 2 Lock menu functions |
| 3 Outbox | 3 Monitor inputs |
| 4 Message settings | 4 Disconnect from network |
| 3 Call register (mobile) | 8 Help |
| 1 Missed | 9 Outgoing call routing |
| 2 Received | 1 Calls via mobile networks |
| 3 Dialed | 2 Prefix of mobile numbers |
| 4 Erase list | 3 Landline International code |
| 4 Divert & forward | 4 Use landline prefix |
| 1 Mobile network divert | 5 Change landline prefix |
| 2 Forward landline | 6 Dial through control |

For full details of all menu options, please see the full user guide.